

**GES** is pleased to have been selected the official service contractor by the Show Organizer to design and produce your show. Our goal is to ensure your show participation is a success.

**GES** is involved in many areas relative to the show and if at any time during the planning process you are unsure where to turn, just ask us, we are at your service.

Please ensure that you review this section carefully as it contains information, **DISCOUNT PRICES** and order forms for each of the many services being provided by **GES**.

For your convenience, we will be offering the following services:

- ✓ **Expresso Online Ordering**
- ✓ **Furnishings**
- ✓ **Carpet & Underpadding**
- ✓ **Specialty Furnishings**
- ✓ **GEM Exhibits & Accessories**
- ✓ **Signs & Graphics**
- ✓ **Plants**
- ✓ **Installation & Dismantling Labour**
- ✓ **In-Booth Forklift**
- ✓ **Material Handling**

To take advantage of our **DISCOUNT PRICING**, all order forms and full payment must be received on or before the Discount Date of **May 11, 2015** as indicated on each form. **GES** accepts Visa, MasterCard, American Express, Cheques and Cash as methods of payment for our services. All exhibitors are responsible for payment of H.S.T. when exhibiting in Ontario.

If you need assistance or additional information, please contact our **Exhibitor Services Department at (905) 283-0500**.



## Accelerate your experience with Expresso exhibit planning, ordering and management.

Exhibitors can order everything they need for their tradeshow exhibit through Expresso, our simple to navigate, picture-driven system that satisfies your need for speed. With just a few clicks exhibitors can order GES products and services including:

- Booth furniture.
- Carpet and flooring.
- Material handling.
- Booth labour.
- And much more.

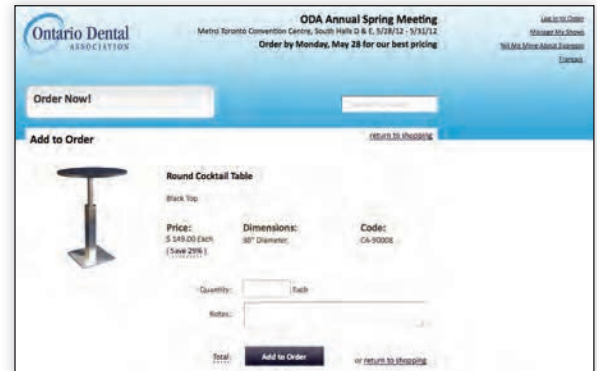

**Expresso is more than just an online exhibitor manual. Exhibitors can:**

- Order exhibit products and services.
- Print shipping labels.
- View important show and event information.
- Download the show schedule into Outlook or iCalendar.
- View account order status and history.

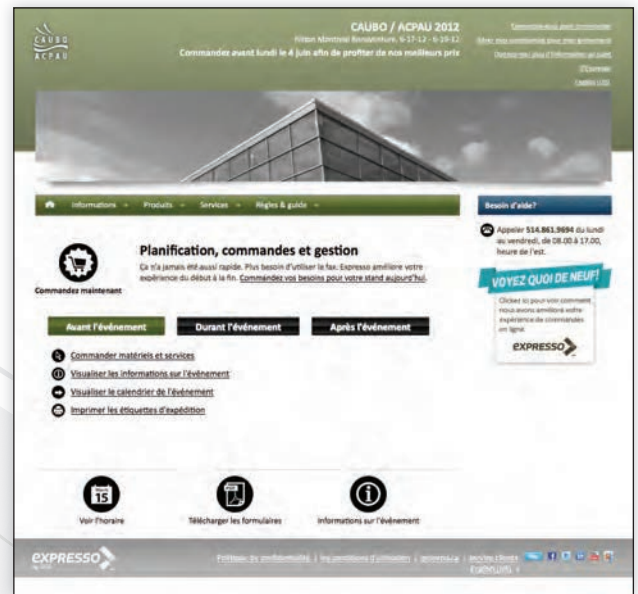

**Experience a difference with Expresso.**

- Each show has their own custom website.
- Runs on all browsers for PCs, Macs and tablets.
- Everything in one place; all organizer and show information, ordering and even third party forms.
- Keeps you on-time and on-budget.





5675 McLaughlin Road, Mississauga, Ontario, L5R 3K5 Tel: 905-283-0500 Fax: 905-283-0501 Toll Free: 1-877-437-4247  
torontoexhibitorservices@ges.com www.gesexpo.ca

**CREDIT CARD AUTHORIZATION**

SHOW: **e-Health 2015**

**EXHIBITOR INFORMATION**

BOOTH #: \_\_\_\_\_

COMPANY \_\_\_\_\_

STREET \_\_\_\_\_

CITY \_\_\_\_\_ PROV/STATE \_\_\_\_\_ CODE \_\_\_\_\_

E-MAIL \_\_\_\_\_

PHONE \_\_\_\_\_ FAX \_\_\_\_\_

CONTACT NAME \_\_\_\_\_

**IMPORTANT - READ CAREFULLY**

**Please fill out The Credit Card Authorization below if:**

- You or your company are forwarding payment to GES in the form of a cheque.
- There is any possibility you or your representative will be ordering any service on-site.
- You are ordering Material Handling, Installation and Dismantle Labour or In-Booth Forklift Services.

**PLEASE COMPLETE THE FOLLOWING**

MASTERCARD     VISA     AMERICAN EXPRESS    EXPIRY DATE:

CORPORATE     PERSONAL

**CARD #**

CARDHOLDER'S NAME (PRINT): \_\_\_\_\_

CARDHOLDER'S SIGNATURE: \_\_\_\_\_

Cardholder's Billing Address: \_\_\_\_\_

City: \_\_\_\_\_ Prov/State: \_\_\_\_\_ Code/Zip: \_\_\_\_\_

Tel: \_\_\_\_\_ Fax: \_\_\_\_\_

This authorization allows GES to charge any fees outstanding after show closing to this credit card (including funds owed due to a cheque returned NSF)

**CHEQUES WILL NOT BE ACCEPTED WITHOUT THIS CREDIT CARD AUTHORIZATION**

**IF THIS AUTHORIZATION IS NOT COMPLETED, ALL ON-SITE ORDERS ARE EXPECTED TO BE PAID IN FULL BEFORE DELIVERY**



5675 McLaughlin Road, Mississauga, Ontario, L5R 3K5 Tel: 905-283-0500 Fax: 905-283-0501 Toll Free: 1-877-437-4247  
 torontoexhibitorservices@ges.com www.gesexpo.ca

**THIRD PARTY BILLING FORM**

SHOW: **e-Health 2015**

**EXHIBITOR INFORMATION**

BOOTH #: \_\_\_\_\_

COMPANY: \_\_\_\_\_

STREET: \_\_\_\_\_

CITY: \_\_\_\_\_ PROV/STATE: \_\_\_\_\_ CODE: \_\_\_\_\_

E-MAIL: \_\_\_\_\_

PHONE: \_\_\_\_\_ FAX: \_\_\_\_\_

CONTACT NAME: \_\_\_\_\_

You may arrange for an exhibit house or other agent to handle your display & be charged for services. GES will agree to this arrangement if the exhibit house or agent makes satisfactory payment arrangements with us. Both firms must complete this form and return to GES by the Discount Price Deadline Date. It is understood and agreed that the exhibitor is ultimately responsible for payment of charges. If your named third party has not paid the invoice before the last day of the show, any outstanding balance will be charged to the exhibitor's credit card.

**Exhibiting Company**

\_\_\_\_\_  
 Name of Exhibiting Company Phone # Fax #

\_\_\_\_\_  
 Address City Prov/State Code/Zip

\_\_\_\_\_  
 Authorized Name (print) Authorized Signature

**CREDIT CARD AUTHORIZATION**

MASTERCARD  VISA  AMERICAN EXPRESS EXPIRY DATE: \_\_\_\_\_

CORPORATE  PERSONAL

CARD # \_\_\_\_\_

\_\_\_\_\_  
 Cardholder's Name (print) Cardholder's Signature

**Third Party / Exhibit House**

\_\_\_\_\_  
 Name of Third Party/Exhibit House Phone # Fax #

\_\_\_\_\_  
 Address City Prov/State Code/Zip

\_\_\_\_\_  
 Authorized Name (print) Authorized Signature

**CREDIT CARD AUTHORIZATION**

MASTERCARD  VISA  AMERICAN EXPRESS EXPIRY DATE: \_\_\_\_\_

CORPORATE  PERSONAL

CARD # \_\_\_\_\_

\_\_\_\_\_  
 Cardholder's Name (print) Cardholder's Signature

**ALL GES SERVICES ARE TO BE CHARGED TO THE THIRD PARTY EXCEPT FOR THE FOLLOWING:**

\_\_\_\_\_

### **DISCOUNT PRICING:**

To qualify for **Discount Pricing**, orders must be received **with payment in full on or before the deadline date.** After the Deadline Date, orders will be charged the **Regular Prices**. Orders without payment cannot be processed until payment is received and could be charged the **Regular Price**.

### **METHOD OF PAYMENT:**

GES accepts American Express, MasterCard, Visa, Debit Card, Cheques, Bank Wire and Electronic Funds Transfers (EFT).

**Exhibitors will be charged a \$25.00 fee for returned NSF cheques.**

### **BANK WIRE AND ELECTRONIC FUNDS TRANSFER INFORMATION:**

To properly credit your account, please complete the **BANK WIRE / EFT FORM** included with the GES order forms.

***NOTE: There is a minimum \$20.00 Service Charge (North America) \$40.00 (International) applicable on all Wire and EFTs. Any additional Wire Transfer and EFT fees are the exhibitors responsibility and may vary depending on the processing bank.***

Please ensure the transfer is made a minimum of 10 days prior to the show.

### **PAYMENT SCHEDULE:**

Payment for all services must be pre-paid in full. GES will not provide Material Handling, In-Booth Forklifts, or Installation and Dismantle Labour Services without your company's **CREDIT CARD AUTHORIZATION FORM** on file.

### **THIRD PARTY BILLING:**

You may arrange for an exhibit house or Third Party to manage your exhibit and order services on your behalf. GES will agree to this arrangement if the exhibit house or agent makes satisfactory payment arrangements with us. In the event the authorized Third Party does not pay, each exhibiting company is ultimately responsible for all charges incurred on its behalf. See **THIRD PARTY BILLING REQUEST FORM**.

### **ADJUSTMENTS AND CANCELLATIONS:**

Adjustments to your invoice **will not be made after the close of the show.** Some items, services and labour are subject to cancellation fees. Refer to each order form for details.

**ALL EXHIBITORS MUST PAY 13% HST ON ALL ORDERS.**





**GES** *Global  
Experience  
Specialists*

# furnishings



Grey Fabric Side Chair



Grey Fabric  
Counter Stool



Grey Fabric Arm Chair



Grey Lounge Chair



Steno Chair



30" Round / 30" High  
Starbase Table



30" Round / 18" High  
Coffee Table



4' and 6' Long  
Skirted Counter  
with White Vinyl Top



4', 6', or 8' Long  
Skirted Table  
with White Vinyl Top



# furnishings



Coat Tree



22" W X 28" H  
Chrome Sign Holder  
(sign extra)

Easel



Gold Ballot Drum



Plexi Pocket  
(Wall Mountable only,  
not self-standing)



40" W x 20" D x 41" H  
White Counter Storage Unit



Bag Holder 41" H



Stanchions  
6' Belt



Plastic  
Wastebasket







5675 McLaughlin Road, Mississauga, Ontario, L5R 3K5 Tel: 905-283-0500 Fax: 905-283-0501 Toll Free: 1-877-437-4247  
torontoexhibitorservices@ges.com www.gesexpo.ca

# FURNISHINGS ORDER FORM

SHOW: **e-Health 2015**

**EXHIBITOR INFORMATION**

**BOOTH #:** \_\_\_\_\_

COMPANY \_\_\_\_\_

STREET \_\_\_\_\_

CITY \_\_\_\_\_ PROV/STATE \_\_\_\_\_ CODE \_\_\_\_\_

E-MAIL \_\_\_\_\_

PHONE \_\_\_\_\_ FAX \_\_\_\_\_

CONTACT NAME \_\_\_\_\_

**DISCOUNT PRICE DEADLINE DATE:** **May 11, 2015**

**CREDIT CARD AUTHORIZATION**

MASTERCARD  VISA  AMEX

\_\_\_\_\_|\_\_\_\_\_|\_\_\_\_\_|\_\_\_\_\_|\_\_\_\_\_|\_\_\_\_\_|\_\_\_\_\_|\_\_\_\_\_|\_\_\_\_\_|\_\_\_\_\_|

EXPIRY DATE \_\_\_\_/\_\_\_\_/\_\_\_\_

\_\_\_\_\_  
CARDHOLDER NAME

\_\_\_\_\_  
CARDHOLDER SIGNATURE

CHEQUE ATTACHED (PAYABLE TO GES CANADA)

**ALL ORDERS MUST BE PREPAID IN FULL (ORDERS CAN NOT BE PROCESSED UNTIL PAYMENT IS RECEIVED)**

FURNISHINGS				
QTY	DESCRIPTION	DISCOUNT PRICE	REGULAR PRICE	TOTAL
	Grey Fabric Side Chair	\$44.00	\$66.00	
	Grey Fabric Counter Stool	\$89.00	\$133.00	
	Grey Fabric Arm Chair	\$63.75	\$95.75	
	Grey Lounge Chair	\$87.00	\$131.00	
	Steno Chair	\$85.75	\$128.75	
	Starbase Table 30" Round 30" High	\$90.25	\$135.25	
	30" Round 18" High Coffee Table	\$71.50	\$106.75	
	Coat Tree	\$39.50	\$59.50	
	22" x 28" Chrome Sign Holder (Sign Extra)	\$80.25	\$121.00	
	Easel	\$50.50	\$76.00	
	Gold Ballot Drum	\$95.75	\$143.00	
	Plexi Pocket (wall mountable only)	\$37.50	\$56.00	
	White Counter Storage Unit 41" H	\$227.75	\$342.00	
	Bag Holder 41"H	\$74.75	\$112.25	
	1 Pair of Stanchions	\$137.50	\$205.75	
	Plastic Wastebasket	\$17.00	\$25.50	

SKIRTED TABLES 30" HIGH				
<input type="checkbox"/> BLACK <input type="checkbox"/> BLUE <input type="checkbox"/> BURGUNDY <input type="checkbox"/> GREEN <input type="checkbox"/> RED <input type="checkbox"/> SILVER <input type="checkbox"/> WHITE				
QTY	DESCRIPTION	DISCOUNT PRICE	REGULAR PRICE	TOTAL
	4 Ft. Long x 2 Ft. Wide	\$88.00	\$132.00	
	6 Ft. Long x 2 Ft. Wide	\$103.50	\$155.00	
	8 Ft. Long x 2 Ft. Wide	\$131.00	\$195.75	
	Skirted Fourth Side	Add \$58.25 ea.		

SKIRTED COUNTER 42" HIGH				
<input type="checkbox"/> BLACK <input type="checkbox"/> BLUE <input type="checkbox"/> SILVER <input type="checkbox"/> WHITE				
QTY	DESCRIPTION	DISCOUNT PRICE	REGULAR PRICE	TOTAL
	4 Ft. Long x 2 Ft. Wide	\$131.00	\$195.75	
	6 Ft. Long x 2 Ft. Wide	\$149.50	\$244.50	
	Skirted Fourth Side	Add \$58.25 ea.		

NON SKIRTED TABLES				
	<input type="checkbox"/> 4 Ft. <input type="checkbox"/> 6 Ft. <input type="checkbox"/> 8 Ft.	\$60.50	\$90.25	
	42" H <input type="checkbox"/> 4 Ft. <input type="checkbox"/> 6 Ft.	Add \$59.50 ea.		

CUSTOM BOOTH DRAPING				
<input type="checkbox"/> BLACK <input type="checkbox"/> BLUE <input type="checkbox"/> RED <input type="checkbox"/> SILVER <input type="checkbox"/> WHITE				
	DESCRIPTION	DISCOUNT PRICE	REGULAR PRICE	TOTAL
	3 Ft. High (Per Linear Ft.)	\$11.50	\$17.50	
	8 Ft. High (Per Linear Ft.)	\$15.50	\$23.00	

**Terms & Conditions**

- All orders received after the Discount Price Date will be processed at the Regular Price.
- Exhibitor is responsible for all items for the duration of the show.
- If a colour is not chosen, GES will choose a colour for you.
- Charges are for rental of equipment only. All items remain the property of GES.
- GES is not responsible for exhibit materials left in GEM rental exhibits or counter storage units.
- All claims or discrepancies must be settled at the GES Service Centre prior to show closing.
- No refunds/exchanges on cancelled skirted tables or custom booth draping once delivered. 50% refund on furnishings cancelled prior to show opening.

<b>SUBTOTAL</b>	
<b>13% HST</b>	
<b>TOTAL</b>	
HST #R104060264	

**I have read and understand the Terms & Conditions of my Agreement with GES.**

\_\_\_\_\_  
**Signature**

\_\_\_\_\_  
**Date**



5675 McLaughlin Road, Mississauga, Ontario, L5R 3K5 Tel: 905-283-0500 Fax: 905-283-0501 Toll Free: 1-877-437-4247  
torontoexhibitorservices@ges.com www.gesexpo.ca

# CARPET ORDER FORM

SHOW: **e-Health 2015**

**DISCOUNT PRICE DEADLINE DATE:** **May 11, 2015**

**EXHIBITOR INFORMATION**

**BOOTH #:** \_\_\_\_\_

COMPANY \_\_\_\_\_

STREET \_\_\_\_\_

CITY \_\_\_\_\_ PROV/STATE \_\_\_\_\_ CODE \_\_\_\_\_

E-MAIL \_\_\_\_\_

PHONE \_\_\_\_\_ FAX \_\_\_\_\_

CONTACT NAME \_\_\_\_\_

**CREDIT CARD AUTHORIZATION**

MASTERCARD     VISA     AMEX

--	--	--	--	--	--	--	--	--	--

EXPIRY DATE \_\_\_\_\_ / \_\_\_\_\_

CARDHOLDER NAME \_\_\_\_\_

CARDHOLDER SIGNATURE \_\_\_\_\_

CHEQUE ATTACHED (PAYABLE TO GES CANADA)

**ALL ORDERS MUST BE PREPAID IN FULL (ORDERS CAN NOT BE PROCESSED UNTIL PAYMENT IS RECEIVED)**

**BOOTH CARPET - STANDARD SIZE**  
*Note: Exhibitors ordering multiple pieces of carpet in this section may not receive the same dyelot.*

QTY.	DESCRIPTION	DISCOUNT PRICE	REGULAR PRICE	TOTAL
	10 Ft. X 10 Ft. Single Booth	\$214.50	\$321.75	
	10 Ft. X 20 Ft. Double Booth	\$365.25	\$547.75	
<b>COLOUR SELECTION:    <input type="checkbox"/> BLACK    <input type="checkbox"/> BLUE    <input type="checkbox"/> GREY    <input type="checkbox"/> RED</b>				

**BOOTH CARPET - CUSTOM SIZE (INCLUDING PLASTIC)**  
*If your booth requires a size not listed above, please complete this section.*

BOOTH SIZE: _____ Ft. x _____ Ft. = _____ Sq. Ft.	\$2.75/Sq. Ft.	\$4.00/Sq. Ft.	
<b>COLOUR SELECTION:    <input type="checkbox"/> BLACK    <input type="checkbox"/> BLUE    <input type="checkbox"/> GREY    <input type="checkbox"/> RED</b>			

**UNDERPADDING PRICE PER SQUARE FOOT INSTALLED (100 SQ. FT. MIN.)**

BOOTH SIZE: _____ Ft. x _____ Ft. = _____ Sq. Ft.	\$1.25/Sq. Ft.	\$2.00/Sq. Ft.	
---	----------------	----------------	--

**PROTECTIVE PLASTIC COVERING PRICE PER SQUARE FOOT INSTALLED (STANDARD SIZES ONLY)**

BOOTH SIZE: _____ Ft. x _____ Ft. = _____ Sq. Ft.	\$0.50/Sq. Ft.	\$0.75/Sq. Ft.	
---	----------------	----------------	--

PLEASE SELECT ONE FOR CUSTOM CARPET SIZES ONLY

**IF ORDERING ELECTRICAL OR TELECOMMUNICATIONS SERVICES, WILL UNDER CARPET WIRING BE REQUIRED?**

YES     NO

**Terms & Conditions**

- All orders received after the Discount Price Date will be processed at the Regular Price.
- Exhibitor is responsible for all items for the duration of the show.
- No refunds/exchanges on carpets once delivered.
- Charges are for rental of equipment only. All items remain the property of GES.
- All claims or discrepancies must be settled at the GES Service Centre prior to show closing.
- If a colour is not chosen, GES will choose a colour for you. *Carpet colour subject to availability.*

<b>SUBTOTAL</b>	
<b>13% HST</b>	
<b>TOTAL</b>	
HST #R104060264	

**I have read and understand the Terms & Conditions of my Agreement with GES.**

\_\_\_\_\_  
Signature

\_\_\_\_\_  
Date

# specialty furniture



Black Ladder Stool



Equino White Stool



White Leather Stool



Red Leather Stool



Black Leather Stool

Chrome Wireback Stool



White Sculpted Leather Chair



*Also available in black or red*

White Sculpted Leather Loveseat

24" Square Chrome/White Cocktail Table



30" Round Cocktail Table Black Top

30" Square Cocktail Table Black Top



Throw Pillows



Available in:



Black Corbusier Leather Chair



*Also available in white or red*

Black Corbusier Leather Loveseat



Still can't find it?

For more options please contact the Exhibitor Services Department **905.283.0500**

[torontoexhibitorservices@ges.com](mailto:torontoexhibitorservices@ges.com)

# specialty furniture



42" Round Black Meeting Table



Grey Leather Ripple Sled Base Meeting Chair



Black Leather Ripple Sled Base Meeting Chair



Bar Fridge



Literature Stand



White Meeting Chair



Round Meeting Chairs



48" Black Coffee Table



72" Chrome & White Meeting Table



48" White Coffee Table



24" Round End Table White Top



24" Round End Table Black Top



Also available in 39" round coffee tables

32" Round Coffee Table Black Top



32" Round Coffee Table White Top



Black Round Tub Chairs



White Round Tub Chairs



Still can't find it?

For more options please contact the Exhibitor Services Department **905.283.0500**

[torontoexhibitorservices@ges.com](mailto:torontoexhibitorservices@ges.com)



5675 McLaughlin Road, Mississauga, Ontario, L5R 3K5 Tel: 905-283-0500 Fax: 905-283-0501 Toll Free: 1-877-437-4247  
torontoexhibitorservices@ges.com www.gesexpo.ca

# SPECIALTY FURNITURE ORDER FORM

SHOW: **e-Health 2015**

**EXHIBITOR INFORMATION**

**BOOTH #:** \_\_\_\_\_

COMPANY \_\_\_\_\_

STREET \_\_\_\_\_

CITY \_\_\_\_\_ PROV/STATE \_\_\_\_\_ CODE \_\_\_\_\_

E-MAIL \_\_\_\_\_

PHONE \_\_\_\_\_ FAX \_\_\_\_\_

CONTACT NAME \_\_\_\_\_

**DISCOUNT PRICE DEADLINE DATE:** **May 11, 2015**

**CREDIT CARD AUTHORIZATION**

MASTERCARD  VISA  AMEX

--	--	--	--	--	--	--	--

EXPIRY DATE \_\_\_\_ / \_\_\_\_

CARDHOLDER NAME \_\_\_\_\_

CARDHOLDER SIGNATURE \_\_\_\_\_

CHEQUE ATTACHED (PAYABLE TO GES CANADA)

**ALL ORDERS MUST BE PREPAID IN FULL (ORDERS CAN NOT BE PROCESSED UNTIL PAYMENT IS RECEIVED)**

QTY	DESCRIPTION	DISCOUNT PRICE	REGULAR PRICE	TOTAL
	Black Ladder Stool (Cloth Seat)	\$149.50	\$224.50	
	Equino White Stool	\$178.25	\$267.50	
	Leather Stool <input type="checkbox"/> white <input type="checkbox"/> red <input type="checkbox"/> black	\$178.25	\$267.50	
	Chrome Wireback Stool	\$186.00	\$279.50	
	Sculpted Leather Chair <input type="checkbox"/> white <input type="checkbox"/> red <input type="checkbox"/> black	\$257.50	\$386.00	
	Sculpted Leather Loveseat <input type="checkbox"/> white <input type="checkbox"/> red <input type="checkbox"/> black	\$349.75	\$524.50	
	Chrome/White Cocktail Table (24" square top, 42" high)	\$167.25	\$250.75	
	Round Cocktail Table (Black 30" diameter top, 42" high)	\$178.25	\$267.25	
	Square Cocktail Table (Black 30" top, 42" high)	\$178.25	\$267.25	
	Corbusier Leather Chair <input type="checkbox"/> white <input type="checkbox"/> red <input type="checkbox"/> black	\$301.50	\$452.00	
	Corbusier Leather Loveseat <input type="checkbox"/> white <input type="checkbox"/> red <input type="checkbox"/> black	\$393.75	\$590.75	
	18" Throw Pillows <input type="checkbox"/> red <input type="checkbox"/> pink <input type="checkbox"/> blue <input type="checkbox"/> white <input type="checkbox"/> orange <input type="checkbox"/> yellow <input type="checkbox"/> black <input type="checkbox"/> green	\$27.50	\$36.50	

QTY	DESCRIPTION	DISCOUNT PRICE	REGULAR PRICE	TOTAL
	42" Black Meeting Table (Round)	\$161.75	\$242.00	
	Leather Ripple Sled Base Meeting Chair <input type="checkbox"/> grey <input type="checkbox"/> black	\$128.75	\$192.50	
	Bar Fridge	\$222.25	\$333.50	
	Literature Stand	\$197.00	\$294.75	
	White Meeting Chair	\$128.75	\$192.50	
	72" Chrome & White Meeting Table	\$260.75	\$390.50	
	Round Meeting Chairs <input type="checkbox"/> white <input type="checkbox"/> red <input type="checkbox"/> black	\$117.75	\$176.00	
	24"x48" Coffee Table <input type="checkbox"/> white top <input type="checkbox"/> black top	\$175.00	\$261.75	
	24" Round End Table <input type="checkbox"/> white top <input type="checkbox"/> black top	\$139.75	\$209.00	
	Round Coffee Table <input type="checkbox"/> 32" <input type="checkbox"/> 39" <input type="checkbox"/> white top <input type="checkbox"/> black top	\$158.50	\$237.50	
	Round Tub Chairs <input type="checkbox"/> white <input type="checkbox"/> black	\$252.00	\$378.50	
<b>NOTE* 3 Seater Sofa Available Upon Request. On-site orders are subject to availability.</b>				

**Terms & Conditions**

- Colours, sizes and styles may vary
- All orders received after the Discount Price Date will be processed at the Regular Price.
- Exhibitor is responsible for all items for the duration of the show.
- There will be no refunds/exchanges for cancellations on-site.
- Charges are for rental of equipment only. All items remain the property of GES.
- All claims or discrepancies must be settled at the GES Service Centre prior to show closing.

<b>SUBTOTAL</b>	
<b>13% HST</b>	
<b>TOTAL</b>	
HST #R104060264	

**I have read and understand the Terms & Conditions of my Agreement with GES.**

\_\_\_\_\_  
**Signature**

\_\_\_\_\_  
**Date**



5675 McLaughlin Road, Mississauga, Ontario, L5R 3K5 Tel: 905-283-0500 Fax: 905-283-0501 Toll Free: 1-877-437-4247  
torontoexhibitorservices@ges.com www.gesexpo.ca

SHOW: <b>e-Health 2015</b>	<b>DISCOUNT PRICE DEADLINE DATE:</b> <b>May 11, 2015</b>				
<b>EXHIBITOR INFORMATION</b>	<b>CREDIT CARD AUTHORIZATION</b>				
<b>BOOTH #:</b> _____ COMPANY _____ STREET _____ CITY _____ PROV/STATE _____ CODE _____ E-MAIL _____ PHONE _____ FAX _____ CONTACT NAME _____	<input type="checkbox"/> MASTERCARD <input type="checkbox"/> VISA <input type="checkbox"/> AMEX <table border="1" style="width:100%; height: 20px; border-collapse: collapse;"> <tr> <td style="width: 25%;"> </td> <td style="width: 25%;"> </td> <td style="width: 25%;"> </td> <td style="width: 25%;"> </td> </tr> </table> EXPIRY DATE ____ / ____ / ____ CARDHOLDER NAME _____ CARDHOLDER SIGNATURE _____ <input type="checkbox"/> CHEQUE ATTACHED (PAYABLE TO GES CANADA)				

# Show Special

→ Spend Less    → Sell More    → Look Great

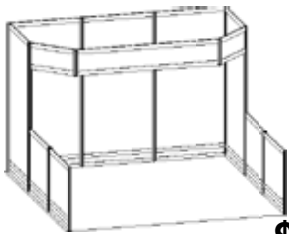

**\$905.50**

**PACKAGE A: 10'x10' BOOTH**

- Header Sign - 12"x78"
- Infill Panels
- Colour Coordinated 10'x10' Carpet
- Price after Deadline Date: **\$1,358.50**

- ✓ Installed and Dismantled
- ✓ Ready before you arrive
- ✓ No Labour Costs
- ✓ No Trucking Costs
- ✓ No Material Handling Costs
- ✓ Includes Carpet
- ✓ Includes Header Sign(s)
- ✓ Choice of Colours
- ✓ Accessories Available

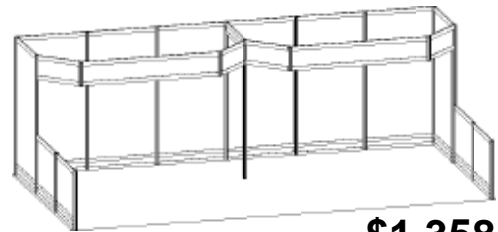

**\$1,358.00**

**PACKAGE B: 10'x20' BOOTH**

- 2 Header Signs - 12"x78" each
- Infill Panels
- Colour Coordinated 10'x20' Carpet
- Price after Deadline Date: **\$2,038.50**

Indicate Date and Time you plan to arrive to merchandise your exhibit: \_\_\_\_\_ Date \_\_\_\_\_ Time \_\_\_\_\_

<b>PLEASE COMPLETE THE FOLLOWING:</b>			
<b>SIZE ORDERED:</b>	<b>PACKAGE A:</b>	<input type="checkbox"/> 10'x10'	<b>PACKAGE B:</b>
Infill Panel Colour:	<input type="checkbox"/> Black <input type="checkbox"/> Grey <input type="checkbox"/> White		<input type="checkbox"/> 10'x20'
Carpet Colour:	<input type="checkbox"/> Black <input type="checkbox"/> Grey		
Package A Identification Sign to Read: _____			
Package B Identification Sign to Read: Left: _____ Right: _____			
<i>(All panel &amp; carpet colours subject to availability.)</i>			
<b>Please upload files to: <a href="https://file.ges.com/">https://file.ges.com/</a></b>			
<input type="checkbox"/> Custom Header to be added			
<b>Custom Header Signs/Logos will be charged \$100.00 extra per sign</b>			
<b>ALL ORDERS MUST BE PREPAID IN FULL (ORDERS CAN NOT BE PROCESSED UNTIL PAYMENT IS RECEIVED)</b>			

**Terms & Conditions**

- Does not include lighting or electrical service.
- No refunds/exchanges once show move-in begins.
- All claims or discrepancies must be settled prior to show closing.
- All orders received after the Discount Price Date will be processed at the Regular Price.
- GES is not responsible for exhibit materials left in GEM rental exhibits or counter storage units.
- Changes to the structure design or graphics will result in additional fees.

<b>SUBTOTAL</b>	
<b>13% HST</b>	
<b>TOTAL</b>	
HST #R104060264	

**I have read and understand the Terms & Conditions of my Agreement with GES.**

\_\_\_\_\_  
Signature

\_\_\_\_\_  
Date



# standard exhibit rentals

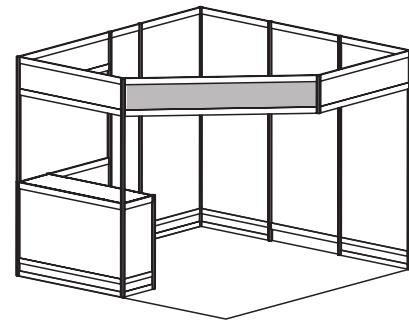

● GEM Model #1 - 10'x10' Corner

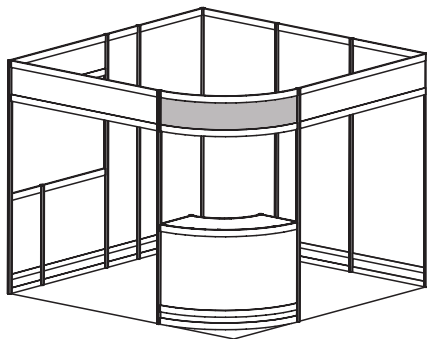

● GEM Model #2 - 10'x10' Corner

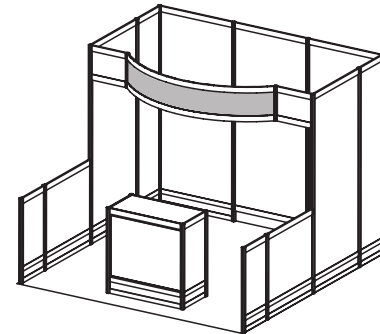

● GEM Model #3 - 10'x10'

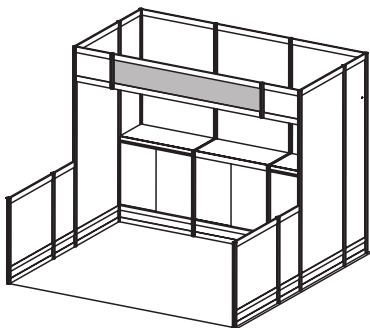

● GEM Model #4 - 10'x10'

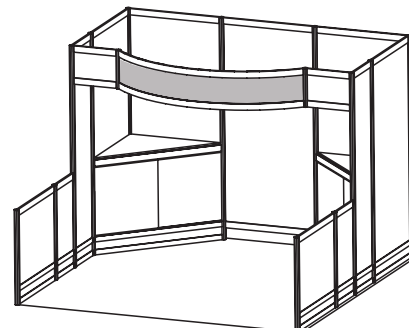

● GEM Model #5 - 10'x10'

## 3 Easy Steps

- 1 Select the model number that suits your needs
- 2 Choose carpet and panel colours on the GEM Exhibit Rental order form
- 3 Complete & send order form

Grey indicates standard header sign(s)



# standard exhibit rentals

**10' X 20'**  
**EXHIBITS**

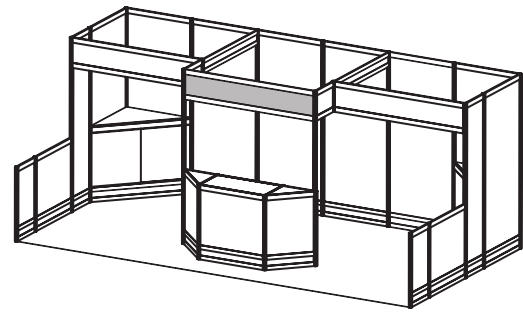

● GEM Model #6 - 10'x20'

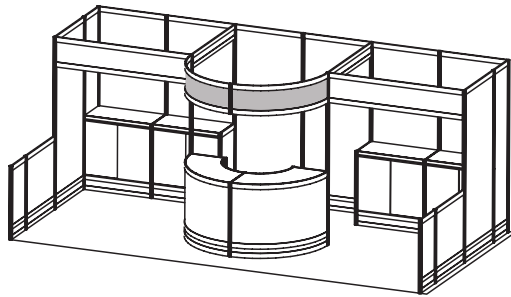

● GEM Model #7 - 10'x20'

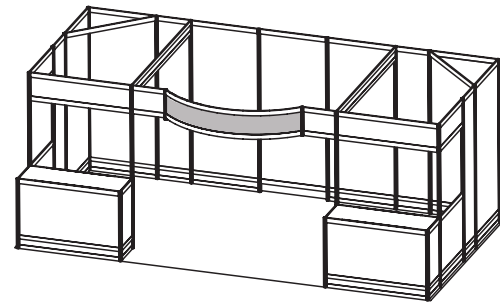

● GEM Model #8 - 10'x20'

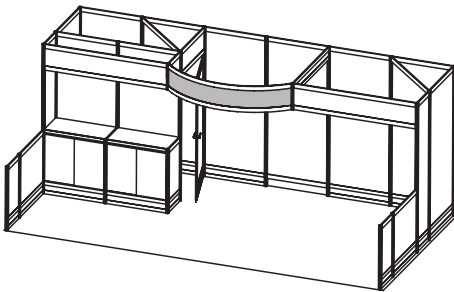

● GEM Model #9 - 10'x20'

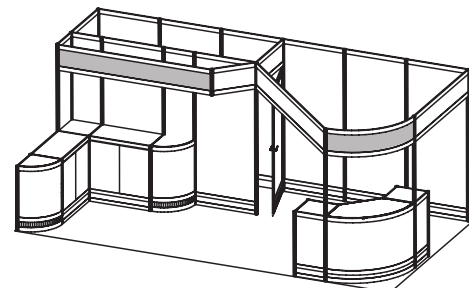

● GEM Model #10 - 10'x20' Corner

## 3 Easy Steps

- 1 Select the model number that suits your needs
- 2 Choose carpet and panel colours on the GEM Exhibit Rental order form
- 3 Complete & send order form

Grey indicates standard header sign(s)



5675 McLaughlin Road, Mississauga, Ontario, L5R 3K5 Tel: 905-283-0500 Fax: 905-283-0501 Toll Free: 1-877-437-4247  
torontoexhibitorservices@ges.com www.gesexpo.ca

# GEM EXHIBIT SYSTEM ORDER FORM

SHOW: **e-Health 2015**

**EXHIBITOR INFORMATION**

**BOOTH #:** \_\_\_\_\_

COMPANY \_\_\_\_\_

STREET \_\_\_\_\_

CITY \_\_\_\_\_ PROV/STATE \_\_\_\_\_ CODE \_\_\_\_\_

E-MAIL \_\_\_\_\_

PHONE \_\_\_\_\_ FAX \_\_\_\_\_

CONTACT NAME \_\_\_\_\_

**DISCOUNT PRICE DEADLINE DATE:** **May 11, 2015**

**CREDIT CARD AUTHORIZATION**

MASTERCARD  VISA  AMEX

\_\_\_\_\_|\_\_\_\_\_|\_\_\_\_\_|\_\_\_\_\_|\_\_\_\_\_|\_\_\_\_\_|\_\_\_\_\_|\_\_\_\_\_|\_\_\_\_\_|\_\_\_\_\_|

EXPIRY DATE \_\_\_\_/\_\_\_\_/\_\_\_\_

\_\_\_\_\_  
CARDHOLDER NAME

\_\_\_\_\_  
CARDHOLDER SIGNATURE

CHEQUE ATTACHED (PAYABLE TO GES CANADA)

**ALL ORDERS MUST BE PREPAID IN FULL (ORDERS CAN NOT BE PROCESSED UNTIL PAYMENT IS RECEIVED)**

Model Number	Discount Price	Regular Price	Model Number	Discount Price	Regular Price
<b>Model #1</b>	\$1,876.50	\$2,815.00	<b>Model #6</b>	\$3,968.75	\$5,953.25
<b>Model #2</b>	\$1,663.00	\$2,494.75	<b>Model #7</b>	\$4,106.50	\$6,159.00
<b>Model #3</b>	\$1,981.00	\$2,971.00	<b>Model #8</b>	\$3,827.00	\$5,739.75
<b>Model #4</b>	\$2,162.50	\$3,244.00	<b>Model #9</b>	\$4,026.00	\$6,039.00
<b>Model #5</b>	\$2,204.50	\$3,306.50	<b>Model #10</b>	\$4,521.00	\$6,781.50

**Package Includes: Installation & Dismantling, Choice of Carpet Colour, Choice of Panel Colour, Company Identification Sign**

**Package Does Not Include: Cleaning, Light Fixtures or Electrical Outlets**

**PLEASE COMPLETE THE FOLLOWING:** MODEL NUMBER:  *Upgrade options available. Contact Exhibitor Services.*

Infill Panel Colour:  Black  Grey  White *Other panel colours available upon request. Contact Exhibitor Services.*

Carpet Colour:  Black  Blue  Grey  Red *(All panel & carpet colours subject to availability.)*

Models 1, 2, 3, 4, 5, 6, 8 or 9 Identification Sign to Read: \_\_\_\_\_

Models 7 or 10 Identification Sign to Read: Left: \_\_\_\_\_ Right: \_\_\_\_\_

Indicate Date & Time for Arrival: \_\_\_\_\_

**Custom Header Signs/Logos will be charged \$100.00 extra per sign**

**ALL ORDERS MUST BE PREPAID IN FULL**  
**(ORDERS CAN NOT BE PROCESSED UNTIL PAYMENT IS RECEIVED)**

**Terms & Conditions**

- Payment may be made by cheque up to two weeks prior to the 1<sup>st</sup> day of move in.
- All orders received after the Discount Price Date will be processed at the Regular Price.
- Exhibitor is responsible for all items for the duration of the show.
- Charges are for rental of equipment only. All items remain the property of GES.
- No refunds/exchanges once show move-in begins. All claims or discrepancies must be settled prior to show closing.
- GES is not responsible for exhibit materials left in GEM rental exhibits or counter storage units.
- Changes to the structure design or graphics will result in additional fees.

<b>SUBTOTAL</b>	
<b>13% HST</b>	
<b>TOTAL</b>	
	HST #R104060264

**I have read and understand the Terms & Conditions of my Agreement with GES.**

\_\_\_\_\_  
**Signature**

\_\_\_\_\_  
**Date**

5675 McLaughlin Road, Mississauga, Ontario, L5R 3K5 Tel: 905-283-0500 Fax: 905-283-0501 Toll Free: 1-877-437-4247  
torontoexhibitorservices@ges.com www.gesexpo.ca

SHOW: **e-Health 2015**

**EXHIBITOR INFORMATION**

**BOOTH #:** \_\_\_\_\_

COMPANY \_\_\_\_\_

STREET \_\_\_\_\_

CITY \_\_\_\_\_ PROV/STATE \_\_\_\_\_ CODE \_\_\_\_\_

E-MAIL \_\_\_\_\_

PHONE \_\_\_\_\_ FAX \_\_\_\_\_

CONTACT NAME \_\_\_\_\_

**DISCOUNT PRICE DEADLINE DATE:** **May 11, 2015**

**CREDIT CARD AUTHORIZATION**

MASTERCARD  VISA  AMEX

\_\_\_\_\_|\_\_\_\_\_|\_\_\_\_\_|\_\_\_\_\_|\_\_\_\_\_|\_\_\_\_\_|\_\_\_\_\_|\_\_\_\_\_|

EXPIRY DATE \_\_\_\_/\_\_\_\_/\_\_\_\_

CARDHOLDER NAME \_\_\_\_\_

CARDHOLDER SIGNATURE \_\_\_\_\_

CHEQUE ATTACHED (PAYABLE TO GES CANADA)

**ALL ORDERS MUST BE PREPAID IN FULL (ORDERS CAN NOT BE PROCESSED UNTIL PAYMENT IS RECEIVED)**

QTY	#	DESCRIPTION	DISCOUNT PRICE	REGULAR PRICE	TOTAL
	1	Pedestal (White) 20"L x 20"W □ 28"H or □ 36"H	\$140.75	\$211.25	
	2	Pedestal White 40"L X 40"W (Tops are 20" X 20") (Unit Heights - 16"- 28" & 28"- 41")	\$510.50	\$765.50	
	3	Storage Counter (White) 80"L X 20"W X 41"H	\$424.50	\$637.00	
	4	Curved Counter (White) 60"L X 20"W X 41"H	\$337.75	\$506.00	
	5	99A Showcase (White/Glass) 40"L X 20"W X 41"H	\$337.75	\$506.00	
	6	99B Showcase (White/Glass) 40"L X 20"W X 41"H	\$337.75	\$506.00	
	7	99C Showcase (White/Glass) 26"L X 26"W X 96"H	\$509.50	\$763.50	
	8	99D Showcase (White/Glass) 40"L X 20"W X 96"H	\$509.50	\$763.50	

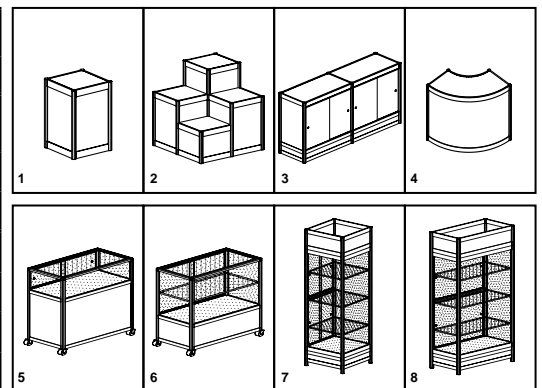

QTY	#	DESCRIPTION	DISCOUNT PRICE	REGULAR PRICE	TOTAL
	A	Waterfall With Eight Balls	\$41.75	\$62.75	
	B	Grid Panels - 38"W X 44"H White Panels (2" Squares)	\$140.75	\$211.25	
	C	Garment Rail 39"W	\$49.50	\$74.75	
	D	Shelves □ Flat □ Angled 37"L X 12"W	\$43.00	\$65.00	
	E	Slatwall Panels - 37"W X 96"H Grey (Upgrade for standard panels)	\$118.75	\$178.25	

*Accessories A to E are designed to fit GES Hardwall booths only*

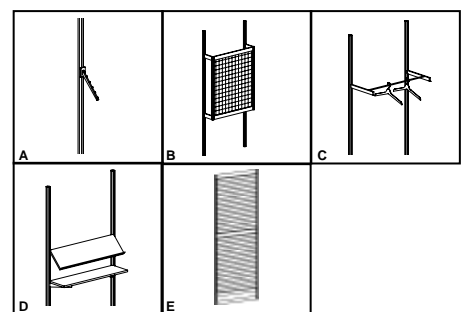

**Please Attach Diagram Of Booth Indicating Locations For Grid Panels And/Or Slatwall. Grid Panels Cannot Be Installed In Corners.**

**Terms & Conditions**

- All items subject to availability.
- No refunds/exchanges once show move-in begins.
- All claims or discrepancies must be settled prior to show closing.
- Exhibitor is responsible for all items for the duration of the show.
- Charges are for rental of equipment. All items remain the property of GES.
- All orders received after the Discount Price Date will be processed at the Regular Price.

<b>SUBTOTAL</b>	
<b>13% HST</b>	
<b>TOTAL</b>	
	HST #R104060264

**I have read and understand the Terms & Conditions of my Agreement with GES.**

\_\_\_\_\_  
Signature

\_\_\_\_\_  
Date



**Our Creative Exhibit Team will design a cost-effective, turnkey exhibit that will**

- Exceed your expectations
- Highlight your brand
- Attract positive attention
- Stay within your budget

**Your successful Tradeshow is just a phone call or click away...**

**Jodi Anastasakis** • 905-283-0559  
 • [janastasakis@ges.com](mailto:janastasakis@ges.com)

**20' x 20' island**



**10' x 20' inline**



**20' x 30' island**



**10' x 20' corner**





5675 McLaughlin Road, Mississauga, Ontario, L5R 3K5 Tel: 905-283-0500 Fax: 905-283-0501 Toll Free: 1-877-437-4247  
torontoexhibitorservices@ges.com www.gesexpo.ca

# SIGN ORDER FORM

SHOW: **e-Health 2015**

**EXHIBITOR INFORMATION**

**BOOTH #:** \_\_\_\_\_

COMPANY \_\_\_\_\_

STREET \_\_\_\_\_

CITY \_\_\_\_\_ PROV/STATE \_\_\_\_\_ CODE \_\_\_\_\_

E-MAIL \_\_\_\_\_

PHONE \_\_\_\_\_ FAX \_\_\_\_\_

CONTACT NAME \_\_\_\_\_

**DISCOUNT PRICE DEADLINE DATE:** **May 11, 2015**

**CREDIT CARD AUTHORIZATION**

MASTERCARD  VISA  AMEX

--	--	--	--	--	--	--	--	--	--	--	--

EXPIRY DATE \_\_\_\_ / \_\_\_\_

CARDHOLDER NAME \_\_\_\_\_

CARDHOLDER SIGNATURE \_\_\_\_\_

CHEQUE ATTACHED (PAYABLE TO GES CANADA)

**ALL ORDERS MUST BE PREPAID IN FULL (ORDERS CAN NOT BE PROCESSED UNTIL PAYMENT IS RECEIVED)**

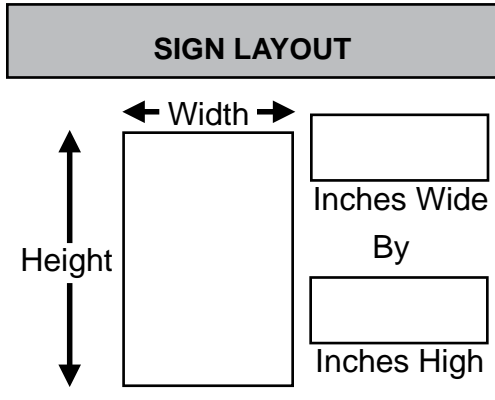

Sign Sizes	Discount Price	Regular Price
11" x 14"	\$ 43.00	\$ 65.00
14" x 22"	\$ 76.00	\$114.50
22" x 28"	\$ 99.00	\$148.50
7" x 44"	\$ 72.50	\$109.00
28" x 44"	\$126.50	\$190.25
40" x 60"	\$277.25	\$415.75

**LOGOS ARE NOT INCLUDED IN PRICING**

**PLEASE PRINT OR TYPE WORDING REQUIRED:**

**ALL SIGNS MUST BE PICKED UP FROM OUR ON-SITE SERVICE DESK.**

**Terms & Conditions**

- All orders received after the Discount Price Date will be processed at the Regular Price.
- There are no refunds/exchanges on signs.
- All claims or discrepancies must be settled at the GES Service Centre prior to show closing.

<b>SUBTOTAL</b>	
<b>13% HST</b>	
<b>TOTAL</b>	
HST #R104060264	

**I have read and understand the Terms & Conditions of my Agreement with GES.**

\_\_\_\_\_  
**Signature**

\_\_\_\_\_  
**Date**

GES is your one stop exhibit solution partner. Take advantage of our Creative Services Department to enhance your presence on the show floor. Upgrade a show special, or design from scratch. Our team of in-house Designers & Production Technicians, can help you realize your vision quickly and affordably.



- Backlit signs
- Banners & hanging signs
- Floor/carpet decals
- Backwall murals
- Easel & freestanding signs
- Posters
- Custom cut signs & decals
- Branding graphics

Please contact Jodi Anastasakis: 905.283.0559

or email: [janastasakis@ges.com](mailto:janastasakis@ges.com)

5675 McLaughlin Road, Mississauga, Ontario, L5R 3K5 Tel: 905-283-0500 Fax: 905-283-0501 Toll Free: 1-877-437-4247  
torontoexhibitorservices@ges.com www.gesexpo.ca

SHOW: <b>e-Health 2015</b>	<b>DISCOUNT PRICE DEADLINE DATE:</b> <b>May 11, 2015</b>										
<b>EXHIBITOR INFORMATION</b>											
BOOTH #: _____											
COMPANY _____											
STREET _____											
CITY _____ PROV/STATE _____ CODE _____											
E-MAIL _____											
PHONE _____ FAX _____											
CONTACT NAME _____											
<b>CREDIT CARD AUTHORIZATION</b>											
<input type="checkbox"/> MASTERCARD <input type="checkbox"/> VISA <input type="checkbox"/> AMEX <table style="width: 100%; border-collapse: collapse;"> <tr> <td style="border: 1px solid black; width: 25px; height: 20px;"></td> <td style="border: 1px solid black; width: 25px; height: 20px;"></td> <td style="border: 1px solid black; width: 25px; height: 20px;"></td> <td style="border: 1px solid black; width: 25px; height: 20px;"></td> <td style="border: 1px solid black; width: 25px; height: 20px;"></td> <td style="border: 1px solid black; width: 25px; height: 20px;"></td> <td style="border: 1px solid black; width: 25px; height: 20px;"></td> <td style="border: 1px solid black; width: 25px; height: 20px;"></td> <td style="border: 1px solid black; width: 25px; height: 20px;"></td> <td style="border: 1px solid black; width: 25px; height: 20px;"></td> </tr> </table>											
EXPIRY DATE _____ / _____											
CARDHOLDER NAME _____											
CARDHOLDER SIGNATURE _____											
<input type="checkbox"/> CHEQUE ATTACHED (PAYABLE TO GES CANADA)											

**ALL ORDERS MUST BE PREPAID IN FULL (ORDERS CAN NOT BE PROCESSED UNTIL PAYMENT IS RECEIVED)**

## Create a Lasting Impression!



GREEN FLOOR PLANTS				
Qty	Description	Discount Price	Regular Price	Total
	2 ft. to 5 ft. Tall	\$77.00	\$155.50	
	6 ft. to 8 ft. Tall	\$106.75	\$159.50	
	9 ft. to 10 ft. Tall (Indoor Tree)	\$158.50	\$237.50	
GREEN TABLE PLANTS				
	Boston Fern	\$45.00	\$67.00	
	Table Plant - 10"	\$45.00	\$67.00	
	Mums	\$28.50	\$43.00	
FLOWERING PLANTS & SPECIAL REQUESTS				
	Standard Fresh Flower Arrangement	\$111.00	\$166.00	
	Premium Fresh Flower Arrangement	\$204.50	\$307.00	
	Exotic Arrangement	\$140.75	\$211.00	



PLEASE NOTE: Prices for flowering plants may change depending on type of flowers requested. Please list below the types of flowers you require along with any specific instructions and our Exhibitor Service Department will check on availability and price:

---



---

**Terms & Conditions**

- All orders received after the Discount Price Date will be processed at the Regular Price.
- Exhibitor is responsible for all items for the duration of the show. No refunds, exchanges or cancellations on site.
- Charges are for rental of equipment only. All items remain the property of GES.
- All claims or discrepancies must be settled at the GES Service Centre prior to show closing.

<b>SUBTOTAL</b>	
<b>13% HST</b>	
<b>TOTAL</b>	
	HST #R104060264

**I have read and understand the Terms & Conditions of my Agreement with GES.**

\_\_\_\_\_  
**Signature**

\_\_\_\_\_  
**Date**



5675 McLaughlin Road, Mississauga, Ontario, L5R 3K5 Tel: 905-283-0500 Fax: 905-283-0501 Toll Free: 1-877-437-4247  
torontoexhibitorservices@ges.com www.gesexpo.ca

# LABOUR SERVICE ORDER FORM

SHOW: **e-Health 2015**

**EXHIBITOR INFORMATION**

BOOTH #: \_\_\_\_\_

COMPANY \_\_\_\_\_

STREET \_\_\_\_\_

CITY \_\_\_\_\_ PROV/STATE \_\_\_\_\_ CODE \_\_\_\_\_

E-MAIL \_\_\_\_\_

PHONE \_\_\_\_\_ FAX \_\_\_\_\_

CONTACT NAME \_\_\_\_\_

**DISCOUNT PRICE DEADLINE DATE:** **May 11, 2015**

**CREDIT CARD AUTHORIZATION**

MASTERCARD  VISA  AMEX

--	--	--	--	--	--	--	--

EXPIRY DATE \_\_\_\_ / \_\_\_\_ / \_\_\_\_

CARDHOLDER NAME \_\_\_\_\_

CARDHOLDER SIGNATURE \_\_\_\_\_

CHEQUE ATTACHED (PAYABLE TO GES CANADA)

**CREDIT CARD AUTHORIZATION (ABOVE) MUST BE COMPLETED AS METHOD OF PAYMENT FOR THIS SERVICE**

LABOUR RATES ARE CHARGED PER PERSON AT **A MINIMUM CHARGE OF ONE HOUR**. LABOUR OVER ONE HOUR IS CHARGED IN 1/2 HOUR INCREMENTS.  
(A 30% SURCHARGE WILL BE APPLIED TO ON-SITE ORDERS)

**Straight Time**  
8:00am - 4:00pm  
Monday - Friday

**\$ 101.00 PER HOUR**

**Overtime**  
4:00pm - 6:00pm  
Monday - Friday  
8:00am - 4:00pm Sat & Sun

**\$151.00 PER HOUR**

**Double Time**  
After 6:00pm Mon-Fri  
After 4:00pm Sat & Sun  
All Holiday Hours

**\$197.00 PER HOUR**

**EXHIBITOR MUST REPORT TO GES SERVICE CENTRE TO RECEIVE THEIR LABOUR**

**INSTALLATION** Set Up Drawings or Photos Attached:  yes  no

Carrier: \_\_\_\_\_ Delivery Date: \_\_\_\_\_ Delivery Time: \_\_\_\_\_  am  pm  
Day / Date/ Month / Year

**SUPERVISION**  By Exhibitor (Provide Name of Rep): \_\_\_\_\_  By GES 30% surcharge applies  
(Exhibitor MUST be Present to Supervise) (Exhibitor does NOT have to be present)

DATE LABOUR REQUIRED: \_\_\_\_\_ START TIME REQUIRED: \_\_\_\_\_  am  pm  
Day / Date/ Month / Year

NUMBER OF PEOPLE REQUIRED  X HOURS PER PERSON  = TOTAL HOURS

**DISMANTLING**

Carrier: \_\_\_\_\_ Pick-up Date: \_\_\_\_\_ Pick-up Time: \_\_\_\_\_  am  pm  
Day / Date/ Month / Year

**SUPERVISION**  By Exhibitor (Provide Name of Rep): \_\_\_\_\_  By GES 30% surcharge applies  
(Exhibitor MUST be Present to Supervise) (Exhibitor does NOT have to be present)

DATE LABOUR REQUIRED: \_\_\_\_\_ START TIME REQUIRED: \_\_\_\_\_  am  pm  
Day / Date/ Month / Year

NUMBER OF PEOPLE REQUIRED  X HOURS PER PERSON  = TOTAL HOURS

**Terms & Conditions**

- When Exhibitor is supervising labour the Exhibitor must check labour in and out at the GES Service Centre.
- We reserve the right to change labourers and/or rates as shifts change.
- All claims or discrepancies must be settled within one week of show closing.
- Uncancelled labour will be charged a minimum fee of 1 hour per person.
- GES Limits of Liability apply.

<b>SUBTOTAL</b>	
<b>13% HST</b>	
<b>TOTAL</b>	
	HST #R104060264

I have read and understand the Terms & Conditions of my Agreement with GES.

\_\_\_\_\_  
Signature

\_\_\_\_\_  
Date





5675 McLaughlin Road, Mississauga, Ontario, L5R 3K5 Tel: 905-283-0500 Fax: 905-283-0501 Toll Free: 1-877-437-4247  
torontoexhibitorservices@ges.com www.gesexpo.ca

**IN BOOTH FORKLIFT ORDER FORM**

SHOW: **e-Health 2015**

**EXHIBITOR INFORMATION**

BOOTH #: \_\_\_\_\_

COMPANY \_\_\_\_\_

STREET \_\_\_\_\_

CITY \_\_\_\_\_ PROV/STATE \_\_\_\_\_ CODE \_\_\_\_\_

E-MAIL \_\_\_\_\_

PHONE \_\_\_\_\_ FAX \_\_\_\_\_

CONTACT NAME \_\_\_\_\_

**DISCOUNT PRICE DEADLINE DATE:** **May 11, 2015**

**CREDIT CARD AUTHORIZATION**

MASTERCARD  VISA  AMEX

--	--	--	--	--	--	--	--	--	--

EXPIRY DATE \_\_\_\_\_ / \_\_\_\_\_

CARDHOLDER NAME \_\_\_\_\_

CARDHOLDER SIGNATURE \_\_\_\_\_

CHEQUE ATTACHED (PAYABLE TO GES CANADA)

**CREDIT CARD AUTHORIZATION (ABOVE) MUST BE COMPLETED AS METHOD OF PAYMENT FOR THIS SERVICE**

IN-BOOTH FORKLIFT SERVICE IS AVAILABLE TO EXHIBITORS REQUIRING ASSISTANCE WITH POSITIONING OF EXHIBITOR MATERIALS WITHIN YOUR BOOTH SPACE. **MINIMUM CHARGE OF 1 HOUR PER ORDER. (INCLUDES INSTALLATION AND DISMANTLING).**

**THIS SERVICE IS NOT PAID FOR BY SHOW MANAGEMENT**

**Straight Time**  
8:00am - 4:00pm  
Monday - Friday

**\$218.00 PER HOUR**

**Overtime**  
4:00pm 6:00pm  
Monday - Friday  
8:00am - 4:00pm Sat & Sun

**\$263.00 PER HOUR**

**Double Time**  
After 6:00pm Mon-Fri  
After 4:00pm Sat & Sun  
All Holiday Hours

**\$311.00 PER HOUR**

A 30% SURCHARGE WILL BE APPLIED TO ON-SITE ORDERS.  
ALL RATES INCLUDE FORKLIFT AND DRIVER (13% HST IS APPLICABLE)

**PLEASE COMPLETE THE FOLLOWING:**

SUPERVISOR NAME: \_\_\_\_\_ (EXHIBITOR MUST BE PRESENT TO SUPERVISE)

INSTALLATION TIME REQUIRED: \_\_\_\_\_ Day \_\_\_\_\_ Date \_\_\_\_\_ Month \_\_\_\_\_ # of Hours \_\_\_\_\_ # of Forklifts \_\_\_\_\_

DISMANTLING TIME REQUIRED: \_\_\_\_\_ Day \_\_\_\_\_ Date \_\_\_\_\_ Month \_\_\_\_\_ # of Hours \_\_\_\_\_ # of Forklifts \_\_\_\_\_

**APPROXIMATE TIMES:**

**MOVE-IN** Start: \_\_\_\_\_  am  pm Finish: \_\_\_\_\_  am  pm Total Hours: \_\_\_\_\_

**MOVE-OUT** Start: \_\_\_\_\_  am  pm Finish: \_\_\_\_\_  am  pm Total Hours: \_\_\_\_\_

**SERVICES OVER 1 HOUR MINIMUM WILL BE CHARGED IN 1/2 HOUR INCREMENTS PER FORKLIFT.**

**Terms & Conditions**

- Exhibitor must check forklift/driver in and out at the GES Service Centre.
- We reserve the right to change labourers and/or rates as shifts change.
- All claims or discrepancies must be settled within one week of show closing.
- GES Limits of Liability apply.

SUBTOTAL	_____
13% HST	_____
TOTAL	_____
HST #R104060264	

I have read and understand the Terms & Conditions of my Agreement with GES.

\_\_\_\_\_  
Signature

\_\_\_\_\_  
Date

## Material Handling Information

### e-Health Show 2015

### Metro Toronto Convention Centre - North Building - Hall B

### May 31 - June 2, 2015

Material Handling is the unloading of your exhibit materials, delivery to your booth, handling of empty containers to and from storage, and removal of your materials from your booth for reloading onto your outbound carrier. This is not to be confused with the cost to transport your exhibit material to and from the event.

#### Benefits of Advance Shipping to the GES Warehouse

- Storage of materials for up to 30 days prior to your show.
- Delivery of Shipments to your booth by 8:00 am on your first day of move-in (schedule permitting).
- Some convention centers and hotels do not have facilities for receiving or storing freight.
- Saves valuable set-up.

#### How to ship in Advance to the GES Warehouse

- Remove all old shipping and empty storage labels.
- Fill out and attach enclosed Advance Shipping Labels.
- Complete the enclosed Material Handling Order Form.
- Remember to confirm receipt of your shipment prior to leaving for the show.
- All shipments must have a bill of lading or delivery slip showing the number of pieces, weight, and type of merchandise.
- Certified Weight Tickets must accompany all shipments.
- Take the time to ensure that your display and products are packed neatly and securely.
- Do not ship uncrated materials to warehouse.

#### How to ship to Exhibit Site

- Consign all shipments c/o GES.
- Remove all old shipping and empty storage labels.
- Fill out and attach enclosed Direct Shipping Labels.
- Complete the enclosed Material Handling Order Form.
- All shipments must have a bill of lading or delivery slip showing the number of pieces, weight, and type of merchandise.
- Certified Weight Tickets must accompany all shipments.
- Take the time to ensure that your display and products are packed neatly and securely.
- If you are shipping your carpet and/or lighting trusses, make sure it is loaded last so it can be unloaded first.

#### Freight Carriers

Select a carrier with experience in handling exhibition materials. Make sure to give your carrier explicit information as to where and when to check in. Delivery and pick up times are often out of the range of "normal" delivery hours, make sure your carrier is committed to meeting your target dates and times. While making shipping plans to the show, also plan for the return shipment.

#### Tracking Shipments

Confirm your delivery date and time with your carrier, and have all pertinent shipping information in the hands of your representative at show site. You may also want to review the return of your goods at the end of the show.

#### Estimating Material Handling Charges

Handling charges are based on the weight of the freight. Shipments are billed by the hundred weight and rounded up to the nearest hundred. Minimum per Shipment may apply, see enclosed Material Handling Order Form for details. Please prepay all shipping charges – GES cannot accept or be responsible for collect shipments. Crated and uncrated shipments must be separated and clearly identified on separate bills of lading with certified weight tickets – otherwise GES will invoice the entire load at the Uncrated rate.

- **Crated** – Material that is skidded, or is in any type of shipping container that can be unloaded at the dock with no additional handling required.
- **Uncrated** – Material that is shipped loose or pad-wrapped, and/or unskidded machinery without proper lifting bars or hooks.

- **Special Handling** – Defined as shipments that are loaded by cubic space and/or packed in such a manner as to require special handling, such as ground loading, side door loading, constricted space loading and designated piece loading or stacked shipments. Also included are mixed shipments and shipments without proper delivery receipts, including certified weight ticket.
- **Off Target/Overtime Surcharges** – Shipments received outside the assigned freight move-in time will be considered off target, and surcharges will apply. Shows that move-out on weekends or late in the day may be subject to overtime surcharges. See enclosed Material Handling Order Form for details.
- **Late Surcharges** – A surcharge will apply if advance freight is received after the published deadline date for shipments to arrive at the warehouse. See enclosed Material Handling Order Form for details.

#### Storing Empty Containers

Properly labeled empty shipping cartons will be picked up, stored, and returned after the show. Labels are available at the GES *Servicenter* or from your GES Service Executive and are for empty storage only. Depending on the size of the show, it can take from two to twelve hours to return empty crates. Do not store any items in crates marked "empty."

#### Outgoing Shipments

An OMHF (Outbound Material Handling Form /Bill of Lading) must accompany all outgoing shipments. Shipping information, outbound forms and labels will be available at the GES *Servicenter*. Exhibitors selecting non-official carriers will need to make their own arrangements for pick-up. Make sure that someone from your company will be on-site to oversee the outbound shipment of your display and product.

#### Machinery Labour and Equipment

Labor and equipment for uncrating, unskidding, positioning, leveling, dismantling, re-crating, and re-skidding machinery and/or equipment must be ordered separately. Place your order for this labor using the In-Booth Forklift & Labor Order Form. If your material requires specialized rigging equipment, please notify us promptly so that we can make arrangements. When possible, supply your own rigging equipment with shipments and pre-rig your material.

#### Insurance

All of your goods should be insured by your own insurance policy. Although we do our best to handle your goods as our own, there are many variables in shipping and handling that can affect your exhibit and products. GES has published GES Terms & Conditions of Contract that are in your exhibitor service manual. Please read them carefully. It is recommended that your goods be insured.

#### GES Limits of Liability & Excess Declared Value

- **Liability** – GES is liable for loss or damage to your goods only if the loss or damage was caused by GES negligence.
- **Measure of Damage** – If GES was negligent and the negligence caused either loss or damage to your goods, then the measure of that damage will be determined by the following:
  - a. Measure of damages in all situations (including b. & c. below) will be limited by the **Depreciated Value** of the goods or repair costs, whichever is less.
  - b. The lesser of **\$0.50** per pound per package, **\$100** per package or **\$1500** per occurrence.
  - c. Damages will be limited to a declared value, if you fill in a **Declared Value Amount**, check the box requesting **Excess Declared Value**, and pay the appropriate charges for **Excess Declared Value**. (Maximum allowed declared value \$100,000)
- **Cost** – Excess declared value available from GES for \$1.00 per \$100 of excess valuation. (\$50.00 minimum charge per request)
- **Not Insurance** – Excess declared value is not insurance. GES does not offer or sell insurance. GES is not liable and will not owe for loss or damage to your goods if the damage or loss was not caused by GES negligence.

**e-Health 2015  
MATERIAL HANDLING RATES**

<b>ADVANCE SHIPMENTS TO WAREHOUSE MAY BEGIN:</b>	<b>May 1, 2015 - May 25, 2015</b>
◆ Crated or Skidded Shipment(s)	\$ 98.00 Per 100lbs.
◆ Special Handling Shipment(s)	\$108.00 Per 100lbs.
◆ Shipments Received After: <b>Monday May 25, 2015</b>	Add 25% Surcharge
◆ Shipments Received Outside Straight Time Hours (Straight Time Hours are Monday-Friday 8am to 4pm)	Add 25% Surcharge
<b>DIRECT SHIPMENTS TO SHOW SITE:</b>	<b>May 31, 2015</b>
◆ Crated or Skidded Shipment(s) – Straight Time	\$ 85.00 Per 100lbs.
◆ Special Handling Shipment(s) - Straight Time	\$100.00 Per 100lbs.
◆ Uncrated, Pad-Wrapped, Loose Shipment(s)	Add 25%
◆ Shipments Received Outside Straight Time Hours (Straight Time Hours are Monday-Sunday 8am to 4pm)	Add 25%
<b>SMALL PACKAGES:</b>	<b>(Maximum 50lbs/Shipment)</b>
◆ First Package	\$ 46.00
◆ Each Additional Package in Shipment (Up to 50lbs.)	\$ 26.00
<b>** If over 50lbs. Maximum – Rates for Advance or Direct Shipments Apply. **</b>	
SMALL PACKAGE: Cartons and envelopes received without documentation will be delivered without guarantee of piece count or condition. Maximum weight is 50 lbs. per shipment, per delivery. Includes UPS and Federal Express shipments. All shipments received via air carrier that do not fall into the small package category may be subject to special handling.	

- NOTE: 1.** All shipment weights when totalled are rounded up to the next 100lbs.  
**2.** All shipments have a minimum billing of 200lbs.

**LABELLING YOUR PACKAGES FOR SHIPPING:**

A) ADVANCE SHIPMENTS TO WAREHOUSE DEADLINE DATE: Friday May 1 - Monday May 25, 2015

<p><b>NAME OF EXHIBITING COMPANY – BOOTH NUMBER</b>  <b>C/O GES / e-Health 2015</b>  <b>6130 Netherhart Road</b>  <b>Mississauga, Ontario, Canada</b>  <b>L5T 1B7</b></p>
---

B) DIRECT SHIPMENTS TO SHOW SITE: Sunday May 31, 2015

<p><b>NAME OF EXHIBITING COMPANY – BOOTH NUMBER</b>  <b>C/O GES / e-Health 2015</b>  <b>Metro Toronto Convention Centre - North Building</b>  <b>Hall B (General Session/food Hall A)</b>  <b>255 Front Street West</b>  <b>Toronto, Ontario, Canada</b>  <b>M5V 2W6</b></p>
--



1. GES CANADA Exposition Services herein known as GES and its subcontractors shall not be responsible for damage to uncrated materials; materials improperly packed, glass breakage or concealed damage.

2. Relative to inbound shipments, there may be a lapse of time between the delivery of shipment(s) to the booth by GES or its subcontractors and the arrival of the Exhibitor's representative at the booth. Similarly, relative to outgoing shipment(s), it is possible that there will be a lapse of time between the completion of packing and the actual pick-up of materials from the booth for loading onto a carrier. It is understood that during such times the shipment(s) will be left in the booth unattended.

Therefore, it is agreed that GES and its subcontractors are not responsible for the loss or disappearance of Exhibitor's materials after the same have been delivered to Exhibitor's booth, nor are GES and its subcontractors responsible for Exhibitor's materials before they are picked up from the Exhibitor's booth for loading after the show. Consequently, all bills of lading covering outgoing shipment(s) submitted to GES or its subcontractors by Exhibitor will be checked at the time of pick-up from the booth and corrected where discrepancies exist.

3. GES and its subcontractors shall not be held liable for any damage incurred during the handling of equipment requiring special devices to properly load, place or reload unless advance notice has been given to GES in time to obtain the proper equipment.

4. GES and its subcontractors shall not be responsible for loss, delay or damage due to strikes, lockouts or work stoppages of any kind.

5. GES and its subcontractors shall not be responsible for ordinary wear and tear in handling of equipment, nor for loss or damage due to fire, theft, windstorm, water, vandalism, acts of God, mysterious disappearance or other causes beyond their control.

6. It is understood that GES and its subcontractors are not insurers. Insurance, if any, shall be obtained by the Exhibitor. Amounts payable to GES hereunder are based on the scope of the liability as herein set forth and are unrelated to the value of the Exhibitor's property. It is further understood and agreed that GES and its subcontractors do not provide for full liability should loss or damage occur. It is agreed that if GES or its subcontractors should be found liable for loss or damage to Exhibitor's equipment, the liability shall be limited to the specific article that was physically lost or damaged. Such liability shall be limited to a sum equal to \$0.30 per pound per article, with a maximum liability of \$50.00 per item or \$1,000.00 per shipment, whichever is less, as agreed upon damages and exclusive remedy. Provisions of this paragraph shall apply if loss or damage, regardless of cause or origin, results directly or indirectly to property through performance services to

Exhibitor's or from negligence, active or otherwise, by GES, its subcontractors or their employees.

7. GES and its subcontractors shall not be liable to any extent whatsoever for any actual, potential or assumed loss of profits or revenues or for any collateral costs that may result from any loss or damage to Exhibitor's materials which may make it impossible or impracticable to exhibit same.

8. Claims for loss or damage must be submitted to GES by the close of the show. No suit or action shall be brought against GES or its subcontractors more than one year after the cause of action.

9. The Exhibitor agrees, in connection with the receipt, handling, temporary storage and reloading of its materials, that GES and its subcontractors will provide these services as Exhibitor's agent and not as bailee or shipper. If any employee of GES or its subcontractors shall sign a delivery receipt, bill of lading or other document, we agree that GES or its subcontractor will do so as the Exhibitor's agent, and the Exhibitor accepts the responsibility thereof.

10. GES and its subcontractors shall not be liable for shipments received without receipts, freight bills or specified unit counts on receipts or freight bills, such as a courier or van lines. Such shipments will be delivered to booth without guarantee of piece count or condition.

11. Empty container labels will be available at the GES Service Centre. Affixing the labels is the sole responsibility of the Exhibitor or its representative. It is understood that these labels are used for EMPTY STORAGE ONLY, and GES and its subcontractors assume no responsibility for loss or damage to contents while containers are in storage or for mislabelled containers.

12. In order to expedite removal of materials from the show site, GES shall have the authority to change designated carriers, if such carriers do not pick up on time. Where no disposition is made by the Exhibitor, materials will be taken to a warehouse to await Exhibitor's shipping instructions, and the Exhibitor agrees to be responsible for payment of charges relating to such handling at the warehouse. GES assumes no liability as a result of such re-routing or handling.

13. The Exhibitor agrees, in the event of a dispute with GES or its subcontractors relative to any loss or damage to any of your materials or equipment, that the Exhibitor will not withhold payment in any amount due to GES for material handling services or any other services provided by GES or its subcontractors as an offset against the amount of the alleged loss or damage. Instead, the Exhibitor agrees to pay GES prior to the close of the show for all such charges and further agrees that any claim the Exhibitor may have against GES or its subcontractors shall be pursued independently by the Exhibitor as a completely separate transaction to be resolved on its own merits.

The consignment or delivery of a shipment to GES or its subcontractors by an Exhibitor or by any shipper on behalf of the Exhibitor shall be construed as an acceptance by such Exhibitor (and/or other shipper) of the terms and conditions set forth in Sections 1 through 13 above.

**Be sure your materials are insured** from the time they leave your firm until they are returned after the show. It is suggested that Exhibitors arrange all risk coverage. This can usually be done by riders to existing policies. Contact your insurance representative. Be sure your liability insurance is in effect during transit and return of your materials, during storage and at show site.